

Agilent PSA Series Spectrum Analyzers

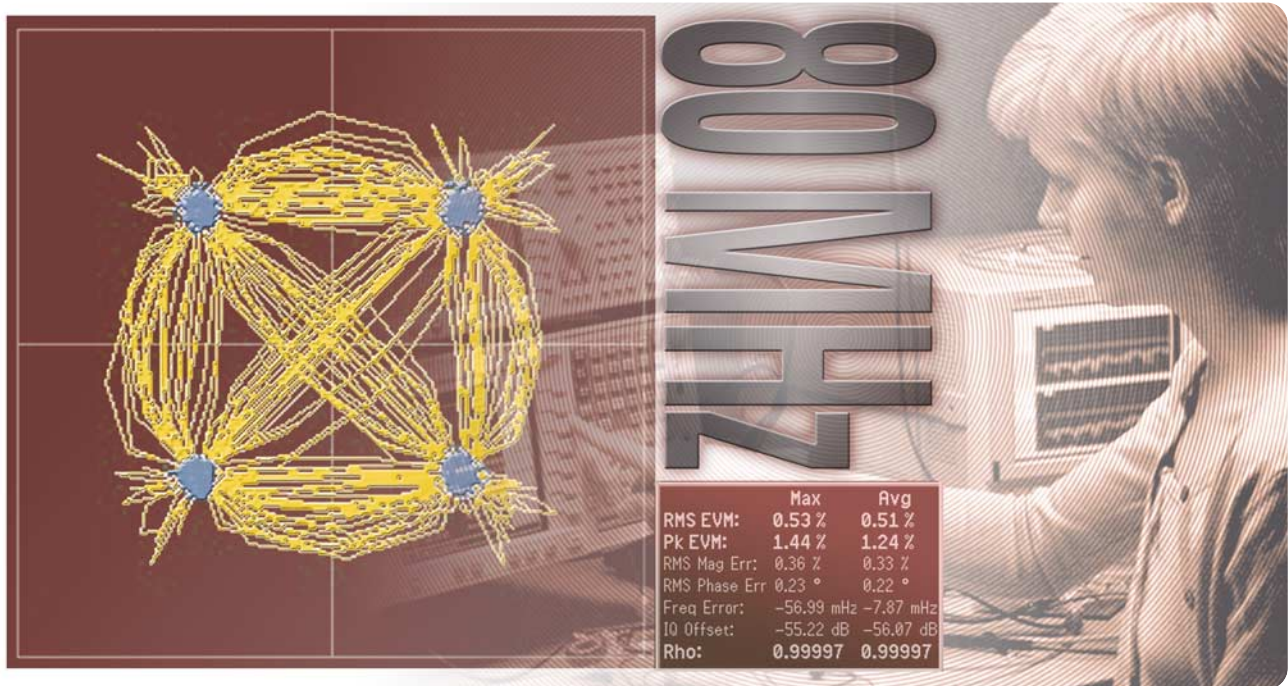

New!

- Built-in flexible modulation analysis
- 80 MHz analysis bandwidth
- EMI measurement capability

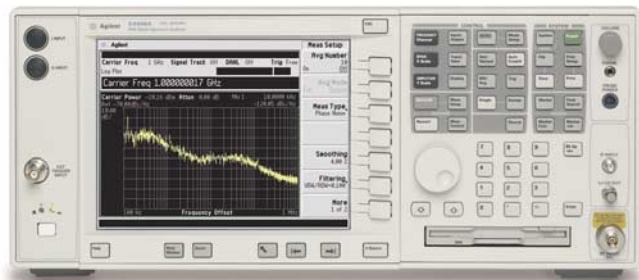

Agilent Technologies

Performance Exceeding Expectations

The brainpower and the will are already yours; the next step is selecting precisely the right tools to reach the market first.

In 1964, Hewlett-Packard Company introduced its first spectrum analyzer at the birth of the technology revolution. Since that time, HP and now Agilent Technologies have continued to be industry leaders in spectrum analysis tools. Today, Agilent offers an entirely new platform for high-performance spectrum analysis.

The Agilent PSA Series offers high-performance spectrum analysis up to 50 GHz and beyond with powerful one-button measurements, a versatile feature set, and a leading-edge combination of flexibility, speed, accuracy, and dynamic range. From millimeter wave and phase noise measurements to spur searches and modulation analysis, the PSA Series offers unique and comprehensive high-performance solutions to R&D and manufacturing engineers in cellular and emerging wireless communications, aerospace, and defense.



Dynamic range

Fine-tune measurements with the industry's most usable dynamic range.



Accuracy

Design with confidence using industry's highest accuracy.



Flexibility

Take control of measurement setups through advanced flexibility.



Speed

Increase throughput and design efficiently with fast measurements.

PSA Series frequency range summary

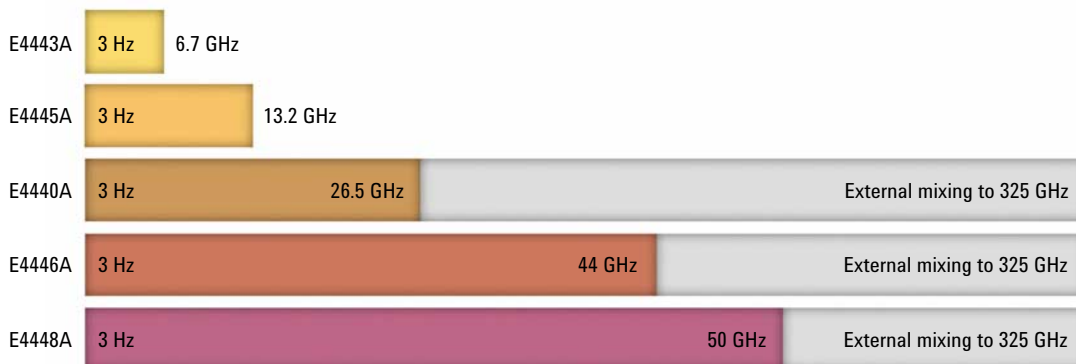

Capability Beyond Limitation

Design efficiently and with confidence

To promote productivity in research and development, test and measurement tools must be flexible, thorough, and easy to use. Troubleshooting and design verification can be expedited and simplified with the PSA Series spectrum analyzers. With this one tool, it is easy to optimize setups for unique spectrum measurements, to customize advanced power measurements for modulated signals, and to dive down to the bit level using the digital demodulation personalities.

Having confidence in measurement results is essential to design verification. Understanding the importance of this, Agilent makes measurement integrity its highest priority. We provide guaranteed technical specifications to a set performance level on which you can depend.

Increase and maintain manufacturing throughput

From high-volume automated testing of cellular base stations to manually tuning oscillators, the PSA Series optimizes manufacturing throughput on many levels.

Increased throughput – Fast 1 ms sweeps, 50 ms ACP measurements, and 45/s update rates reduce automated test times. Manual tests are accelerated by one-button setups and fewer required button presses per measurement. The PSA Series shifts easily between measurement personalities, minimizing changeover time and accelerating troubleshooting.

Improved yields – Excellent specifications reduce measurement uncertainty to allow for narrower test margins and improved yields. Sophisticated algorithms constantly monitor analyzer conditions and determine when internal background alignment is required.

One analyzer, many solutions – Using only 177 mm (7 in) of rack space, the PSA Series is packed with features. Superior accuracy (± 0.17 dB typical) and linearity may eliminate the need for a power meter. Cellular communications measurement personalities give it digital demodulation capability. The phase noise personality transforms it to a phase noise tester. The feature list is long and will continue to grow.



The PSA Series offers a wide variety of features for making more than just traditional spectrum analyzer measurements.

- **Power Suite**
- **Measurement personalities**
- **Modulation analysis**
- **Modern connectivity**

High-Performance Spectrum Analysis

Great specifications are the starting point for great measurements. The PSA Series has the technology to offer unprecedented control over dynamic range, resolution, and speed.

- 2 dB step attenuator**
- 160 RBW settings (10% steps)**
- Optional built-in preamplifier**
- Noise correction** for ACP measurements

- -153 dBm typical DANL
- -166 dBm typical DANL with built-in preamplifier
- +19 dBm typical TOI
- +7 dBm nominal 1-dB gain compression
- -118 dBc/Hz typical phase noise at 10 kHz offset
- 81 dB typical W-CDMA ACPR dynamic range with noise correction

The PSA Series achieves superior linearity and unsurpassed accuracy due to its advanced design and modern technology.

- All-digital auto-ranging IF** reduces or eliminates amplitude uncertainty
- Auto alignment** guarantees accuracy with temperature changes
- Amplitude correction** to compensate for gains and losses in your test setup

- ±0.17 dB typical amplitude accuracy
- 0 dB reference level uncertainty
- 0 dB display switching uncertainty
- ±0.05 dB RBW switching uncertainty
- ±0.07 dB display linearity



Dynamic range

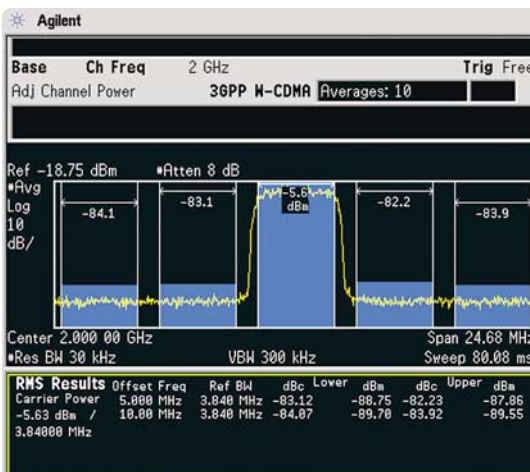

The PSA Series has excellent dynamic range for a W-CDMA adjacent channel power (ACP) measurement

To learn more, read...

Optimizing Dynamic Range for Distortion Measurements,
product note,
literature number
5980-3079EN



Accuracy

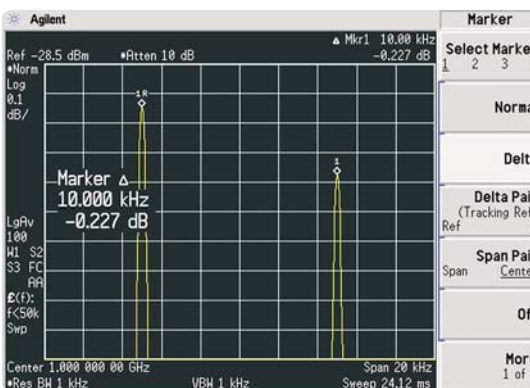

This figure illustrates 0.1 dB/division display resolution, 0.01 dB reference level resolution, and 0.001 marker resolution with averaging.

To learn more, read...

PSA Series Amplitude Accuracy,
product note,
literature number
5980-3080EN

From the novice to the most knowledgeable expert, the PSA makes it easy for anyone to obtain accurate, reliable results from their measurements.



Swept versus FFT

Perform swept-tuned measurements with digital RBW filters or fast Fourier transform (FFT) measurements with digital FFT filters. Use this flexibility to optimize for speed and sensitivity.

Phase noise optimization

The PSA Series' local oscillator (LO) phase lock loop configuration can be set to optimize phase noise close to a carrier within a 50 kHz offset, close to a carrier outside of a 50 kHz offset, or for tuning speed.

Digital detectors

Detector modes become important for accurately measuring different types of continuous wave, noise, and noise-like signals. The PSA Series offers this complete suite of detectors to assure correct measurement results.

- normal
- average (log, rms, voltage)
- peak
- sample
- negative peak
- EMI detectors
(quasi-peak, peak, average)



Choose between swept or FFT measurements and optimize input attenuation and resolution bandwidths to make fast measurements.

- 1 μ s sweep times in zero-span
- 1 ms frequency sweep times
- >50 measurements/second locally
- >45 measurements/second remotely
- 30 ms fast ACP measurements
- Fast low-level spur search

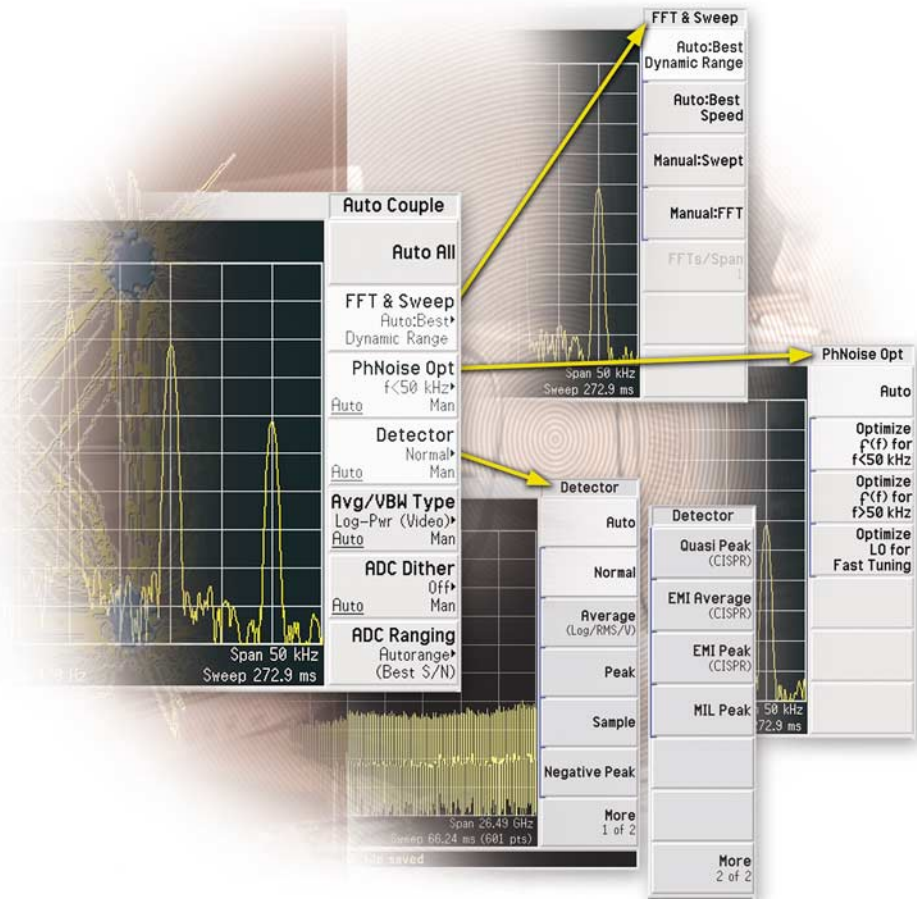

To learn more, read...

PSA Series Swept and FFT Analysis, product note, literature number 5980-3081EN

Power Suite: The Power to Realize

Making broadband signal measurements simple and intuitive requires unique spectrum analyzer measurement capability. The PSA Series offers a comprehensive suite of flexible, one-button RF and microwave power measurements, with wireless format-based setups for 2G/3G, W-LAN, Bluetooth™, UWB, and S-DMB standards. Power Suite is a standard tool set included in every PSA Series spectrum analyzer.

Power Suite measurements

- channel power
- occupied bandwidth
- adjacent channel power (with multiple offsets)
- multicarrier power/12-carrier ACP
- power statistics (CCDF)
- harmonic distortion
- burst power
- third order intercept (TOI)
- spurious emissions
- spectrum emission mask

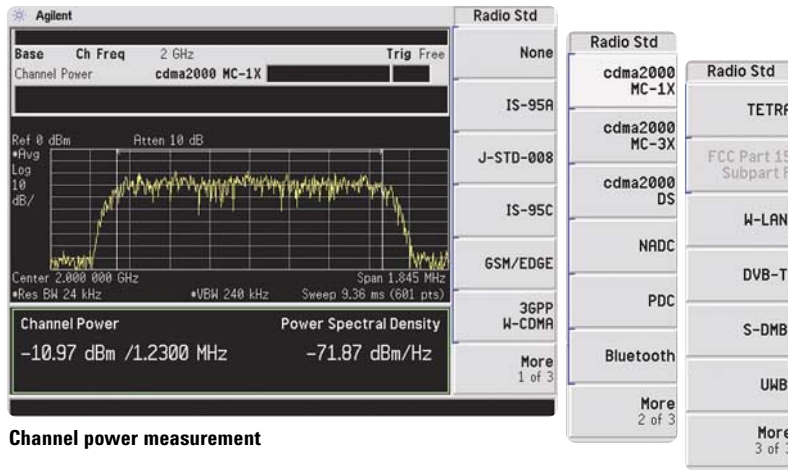

Channel power measurement

NEW EMI Measurements

Perform EMI precompliance measurements using the PSA's built-in CISPR and MIL standards compliant EMI detectors and bandwidths. Avoid costly redesign by measuring the radiated and conducted emissions of your design early in the development process.

Limit Lines

Customizable limit lines for pass/fail testing are standard with every PSA Series spectrum analyzer.

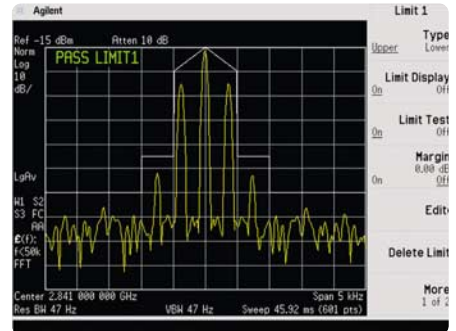

Customize limit lines for pass/fail testing

Gated Sweep

Use the standard, built-in gated sweep capability to analyze time varying signals, such as burst RF or TDMA, without interference from switching the carrier on and off.

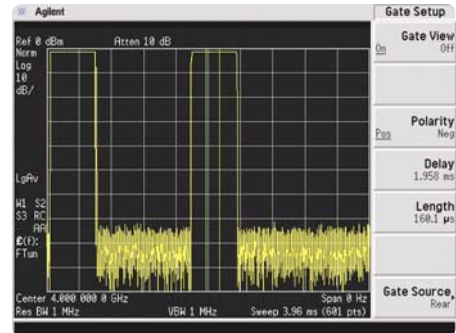

Gated sweep measurement

Measurement Personalities

Conveniently built in to the analyzer, these optional application-specific measurement personalities provide advanced capability with one-button measurement simplicity.

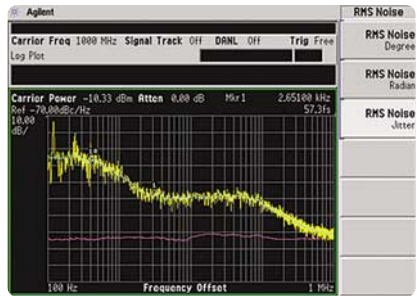

Log plot measurement

Phase noise (Option 226)

This flexible tool quickly and easily generates plots of phase noise in dBc/Hz versus log offset frequency, measures jitter, or makes continuous spot frequency phase noise measurements.

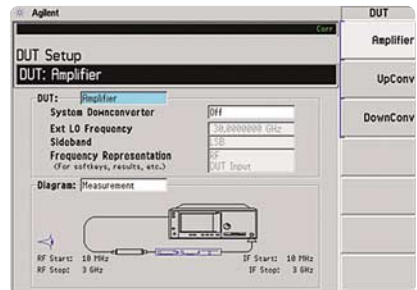

DUT setup menu

Noise figure (Option 219)

Make noise figure and gain measurements from 100 kHz to 26.5 GHz with this personality that offers guides for measurement setups and a built-in uncertainty calculator to qualify the measurement system.

Digital demodulation hardware (Option B7J)

This option, required for format-based modulation analysis, includes a 1-dB electronic step attenuator and provides spectrum and waveform analysis and I/Q pairs over GPIB or LAN.

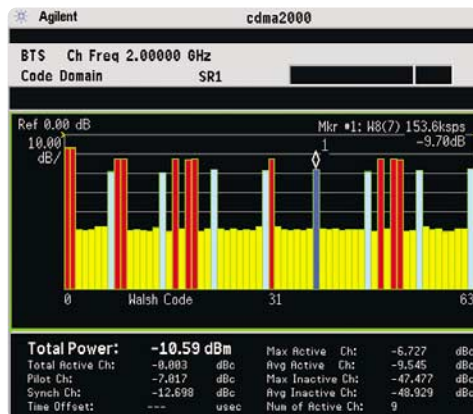

cdma2000 code domain analysis

To learn more, read... Measurement Personality technical overviews, a complete list is available on page 16

NEW **80 MHz bandwidth digitizer (Option 122)**

Capture and measure complex time data with up to 80 MHz of bandwidth, 80 dB (typical) dynamic range, and excellent phase and amplitude flatness using Agilent's advanced interleave technology.

NEW **Flexible digital modulation analysis (Option 241)**

Analyze and measure modulation quality and troubleshoot a wide variety of digitally modulated signals with this built-in flexible tool.

Cellular communications

The PSA Series offers powerful, format-based power measurements and modulation analysis for several popular cellular formats.

- **W-CDMA** (Option BAF) for uplink and downlink
- **HSDPA** (Option 210) enhancement to the W-CDMA option
- **GSM with EDGE** (Option 202) including PvT and ORFS
- **cdma2000** (Option B78) for forward and reverse links
- **1xEV-DV** (Option 214) enhancement to the cdma2000 option
- **1xEV-DO** (Option 204) for forward and reverse links
- **cdmaOne** (Option BAC)
- **TD-SCDMA** (Option 211) power measurements only
- **NADC/PDC** (Option BAE)

Truly User Friendly

The PSA Series has a simple and intuitive user interface. The display is large and bright with effective use of colors. Front panel hard keys perform frequently used functions and provide access to menus. Soft keys on the display are organized for quick and easy navigation. One-button set-ups are provided for many measurements.

Noise source control output for noise figure measurements (Option 219)

Real-time clock for time-stamping of data files and printouts

Display – expand measured results to full screen on the bright, high resolution, wide viewing angle, 17-cm color display

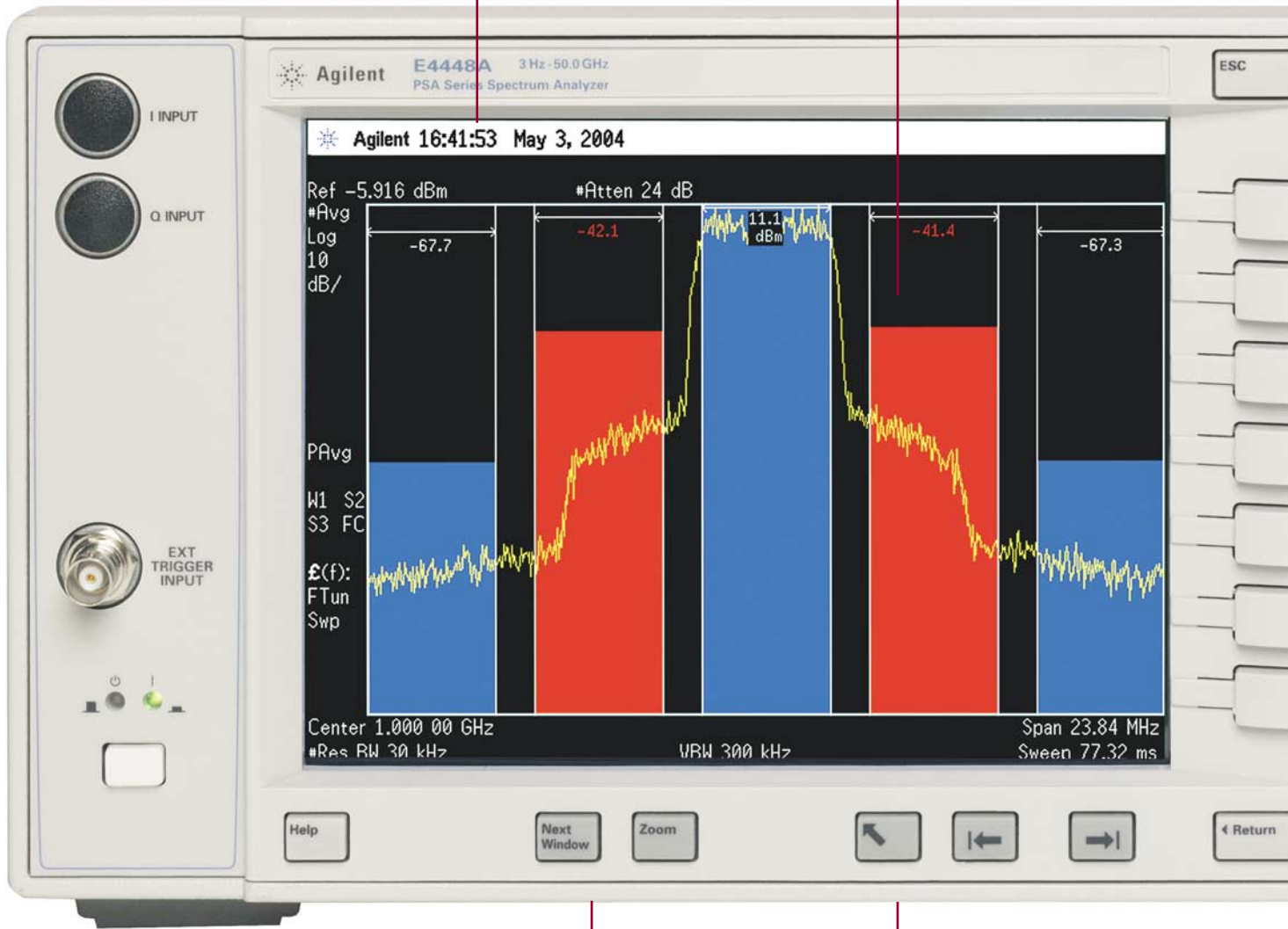

Workstation processor

Automatic background alignment for exceptional accuracy

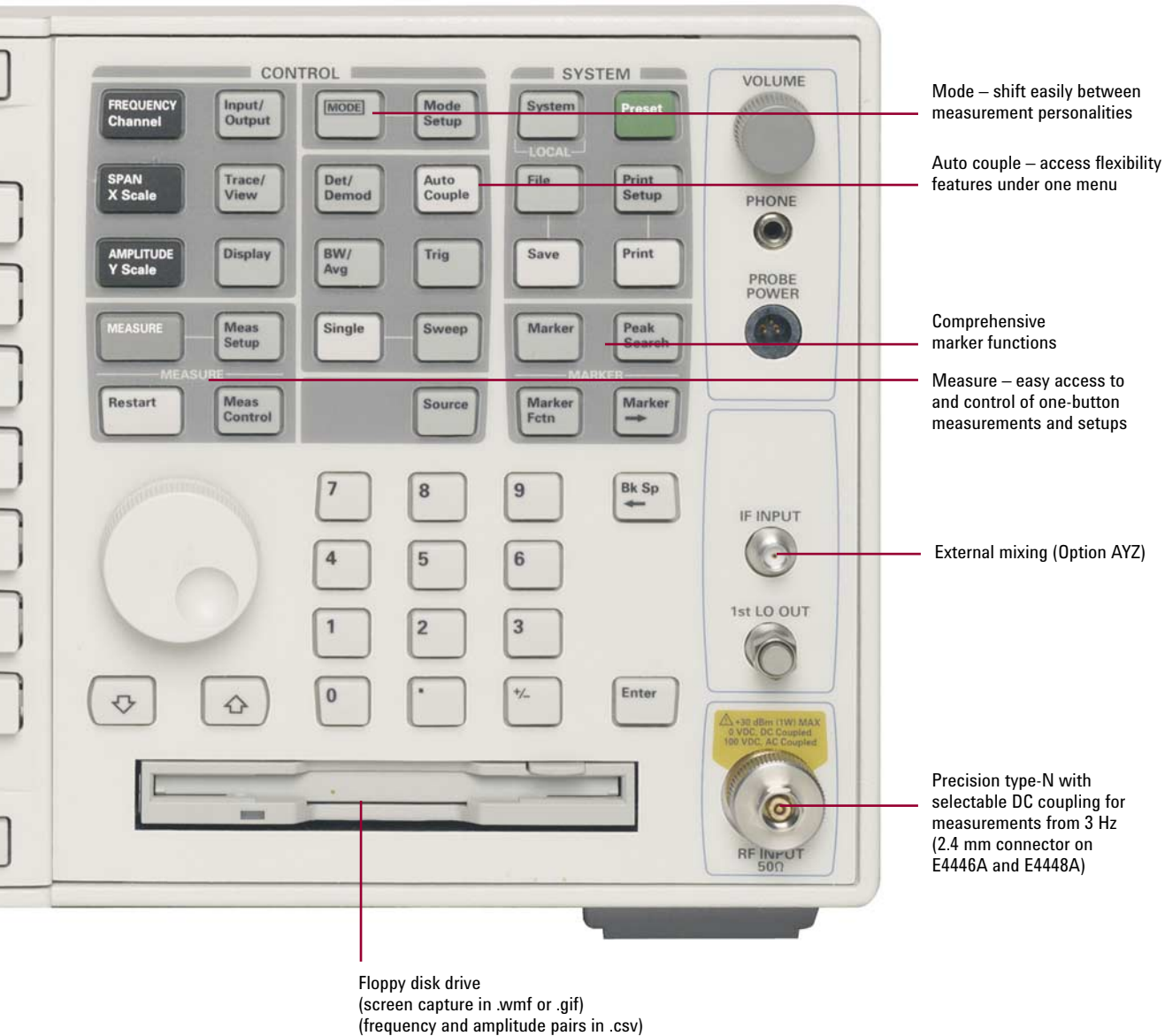
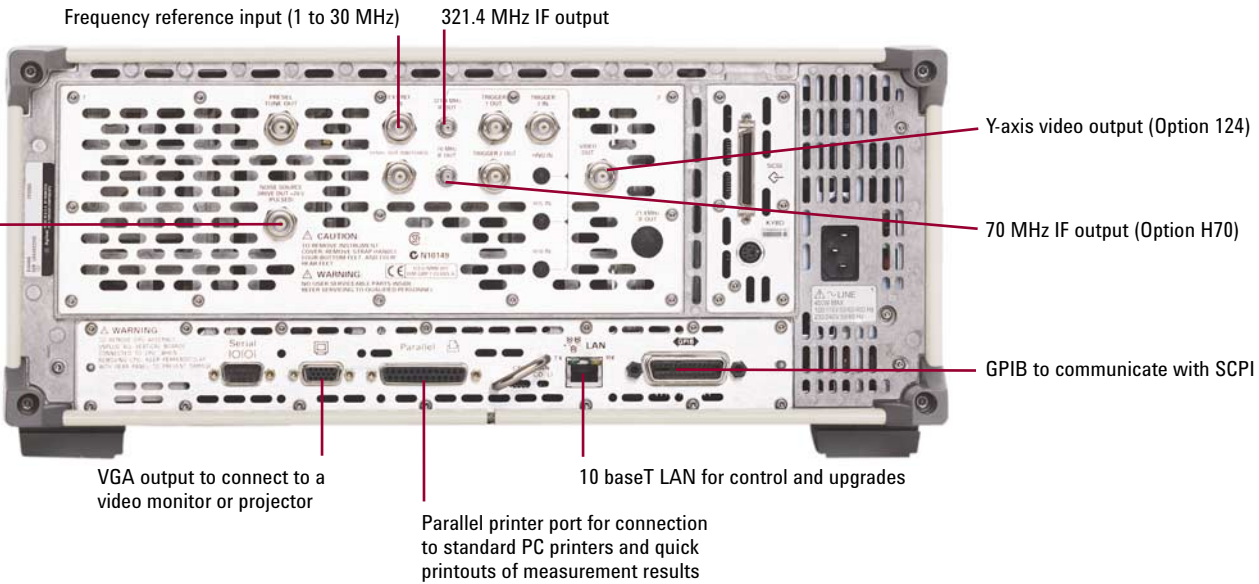

A Spectrum Analyzer with a Digital Brain

Agilent PSA Series block diagram

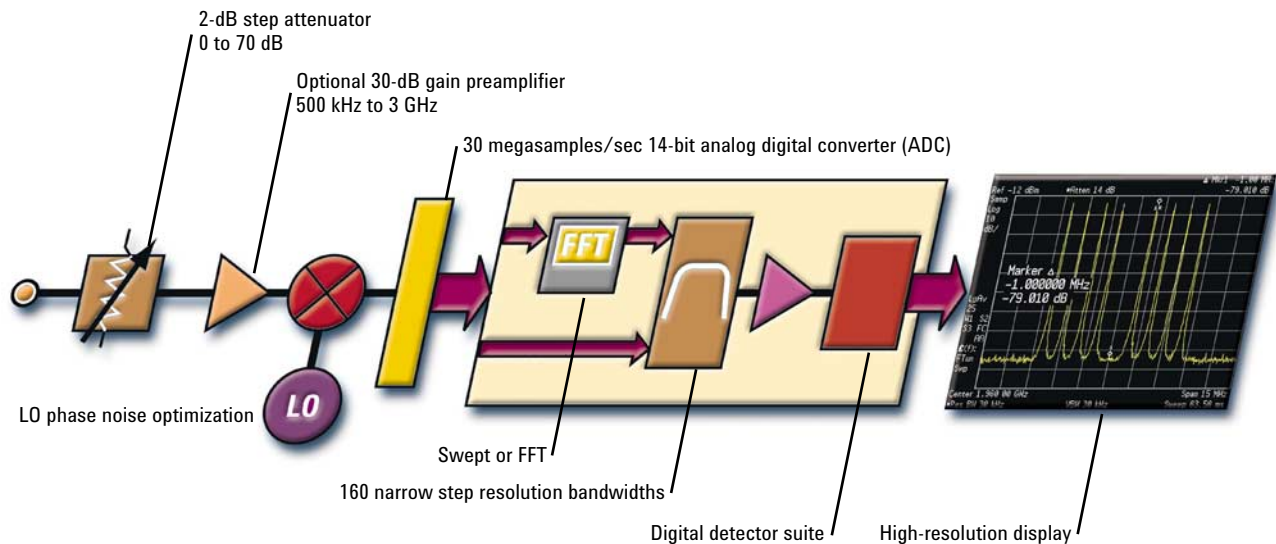

All-digital auto-ranging IF

The PSA Series has an all-digital IF section with auto-ranging capability. After the input signal is downconverted, it is immediately digitized, and all processing is performed digitally. This architecture offers:

- Variable RBW filters in 10% steps
- Exact and predictable resolution bandwidths
- Zero uncertainty in reference level and display scale switching
- Improved filter shape factor
- Faster sweep speeds
- Increased display resolution
- FFT capability
- Multiple detector modes

With auto-ranging, the analyzer adjusts the input signal in real time during the sweep so that the full range of the digitizer is utilized. Thus, at every point in the sweep the signal is being measured with the full resolution and dynamic range of the ADC.

- Signals are measured accurately everywhere on the display.
- Accuracy and linearity do not degrade when measuring small signals in the presence of large signals.
- The dynamic range of the instrument is not limited by the dynamic range of the digitizer.

To learn more, read...

Measurement Innovations and Benefits, product note, literature number 5980-3082EN

Modern Connectivity

Connect

The PSA Series has built-in capability to network with PCs, printers, and software programs. Standard connectivity features include

- **IVI-COM and VXI plug & play** drivers for Agilent VEE, National Instrument's LabView, and LabWindows
- **IntuiLink** software for easy transfer of measurement results into Microsoft® Excel and Word
- **Floppy disk drive**

NEW

NEW

- **GPIB and 10 baseT LAN** for automated control and remote operation
- **SCPI** programmability
- **Code compatibility suite** (Option 266) for easily upgrading your HP 8566B/68B or HP/Agilent 8560 and 8590 Series spectrum analyzers to the PSA Series
- **Y-axis video output** (Option 124)
- **Parallel port for printing**

- **BenchLink Web Remote** (Option 230) used to control analyzer functions, record and evaluate data, and view signals in real time, remotely anywhere in the world over the Web
- **Agilent's Connectivity Suites** and products will enable you to make fast, easy instrument connections and create test programs based on the power of Microsoft Visual Studio/.NET

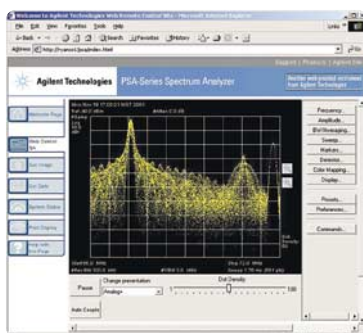

Benchlink Web Remote

For more information, please visit

www.agilent.com/find/connectivity

Advanced modulation analysis with Agilent 89601A vector signal analysis software

For engineers working with today's emerging broadband communication systems, the PC based Agilent 89601A vector signal analysis (VSA) software and the PSA together provide an indispensable tool for basic research and product development.

Evaluate modulated signals, digital and analog, with 80 MHz of analysis bandwidth and 80 dB (typical) of dynamic range (with Option 122). The 89601A vector signal analysis software teams advanced demodulation algorithms with highly flexible scalar and vector analysis tools to help you develop, troubleshoot and verify the physical layer performance of your radio system.

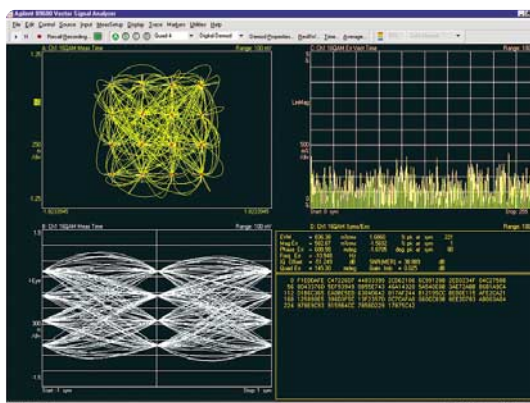

Agilent 89601A vector signal analysis software

Confidence Brings Reward

PSA series specifications

Every PSA Series spectrum analyzer is thoroughly tested and guaranteed to meet the specifications given in the PSA Spectrum Analyzers Specifications Guide and other product literature. With reliable performance, error budgets for measurement uncertainty can be reduced resulting in increased yields, improved device specification settings, and reduction in test setup costs.

Typical performance

Because 80% of PSA Series analyzers typically perform significantly better than the guaranteed specifications, we supply a “typical” value for the more commonly used specifications. Use this typical data when comparing products, or when the application pushes the limit on a given specification.

Performance verification and instrument calibration

All functions and specifications of each PSA are fully calibrated and certified in the Agilent factory. The recommended calibration cycle for the PSA is one year, and Agilent calibration services are available worldwide to support this product. Furthermore, Agilent can provide ANSI Z540 or ISO 17025 conformant and accredited calibrations upon request, which provide detailed data reports and certifications.



To learn more, read...

ISO 17025 Calibration – essential information that will help you win, brochure, literature number 5988-7953EN

Key Specifications¹

E4443A/E4445A/E4440A/E4446A/E4448A

Frequency range 3 Hz to 6.7/13.2/26.5/44/50 GHz
(to 325 GHz with external mixing)

Speed

Sweep time, span \geq 10 Hz 1 ms to 2000 s
 Sweep time span = 0 Hz 1 μ s to 6000 s
 Fast ACP measurement time \leq 30 ms (0.2 dB standard deviation)
 Local measurement update rate \geq 50 measurements/sec
 Remote measurement update rate \geq 45 measurements/sec

Resolution

Resolution bandwidth range, swept and FFT 1 Hz to 3 MHz (10% steps), 4, 5, 8 MHz
 Variable sweep (trace) point range 101 to 8192
 Phase noise at 1 GHz
 10 kHz offset -116 dBc/Hz (-118 dBc/Hz, typical)
 1 MHz offset -145 dBc/Hz (-148 dBc/Hz, nominal)
 10 MHz offset -156 dBc/Hz (-158 dBc/Hz, nominal)

Dynamic range

Displayed average noise level (DANL)
 10 MHz to 3 GHz -152 dBm (-153 dBm typical)
 3 GHz to 20 GHz -147 dBm (-149 dBm typical)
 20 GHz to 26.5 GHz -143 dBm (-145 dBm typical)
 26.5 GHz to 44 GHz -129 dBm (-132 dBm typical)
 44 GHz to 50 GHz -127 dBm (-130 dBm typical)

Preamplifier (DANL), 10 MHz to 3 GHz -165 dBm (-166 dBm typical)
 1 dB gain compression, 200 MHz to 3 GHz +3 dBm (+7 dBm nominal)
 Input attenuator range 0 to 70 dB in 2 dB steps
 TOI, 1.7 GHz to 3.0 GHz +17 dBm (+19 dBm typical)

ACPR, W-CDMA (5 MHz offset)

Dynamic range 74.5 dB typical
 with noise correction 81 dB typical

Accuracy

Absolute amplitude accuracy $\pm(0.24$ dB + frequency response)
 $[\pm(0.06$ dB + frequency response) typical]
 Frequency response, 3 Hz to 3 GHz ± 0.38 dB (± 0.11 dB typical)
 Frequency accuracy (1 GHz) ± 100 Hz
 ACPR, W-CDMA accuracy (5 MHz offset)
 Mobile station ± 0.12 dB
 Base station ± 0.22 dB

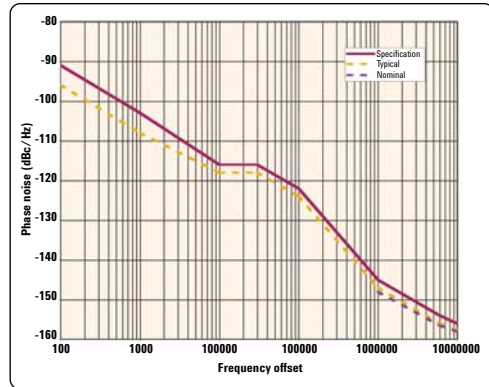

PSA Series phase noise performance plot (1 GHz center frequency)

To learn more, read...

**PSA Series,
data sheet,
literature number
5980-1284E**

1. See PSA Series spectrum analyzers data sheet for more specification details (literature number 5980-1284E).

Service and Support

The performance and flexibility of the PSA Series spectrum analyzer is only a small part of what is available from Agilent. In a constantly changing environment, Agilent's ability to understand your business needs and quickly provide the latest end-to-end service and support solutions gives the certainty and confidence necessary to accelerate the development and deployment of winning technologies.

Support solutions

Use Agilent's support solutions to get more from the PSA, as well as other test equipment, by increasing productivity and maximizing up-time. Our programs are designed with flexibility and can be tailored to meet your needs, including costs and response times.

Repair services ensure that the instrument is up and running as quickly as possible. The PSA comes with a one-year return-to-Agilent warranty. Extended warranty and technical support options are available at the time of purchase.

Agilent Calibration services are available worldwide to insure PSA measurement confidence to its original factory shipped condition. Choose return-to-Agilent or on-site calibration services. Upfront calibration plans available at the time of purchase provide the best value.

Volume On-site Calibration (VOSCAL) service minimizes instrument downtime and associated costs by delivering quality calibration on-site without interfering with output schedules. VOSCAL is a fully operational, high-quality mobile calibration laboratory complete with high-specification systems and automation.

System up-time services provide Agilent's global resources and expertise to help prevent system failures and develop solutions to problems fast. Our system up-time teams are comprised of our best service specialists to keep systems up and running.

Equipment management services assist in managing test and measurement assets. Agilent's global equipment management solution helps maximize the utilization and reduce the ownership cost of test equipment.

For more information on Agilent support solutions visit:

www.agilent.com/find/tm_services

Knowledge services

Our goal at Agilent is to provide the key resources that will help you build the comprehensive solutions to stay competitive. Agilent's knowledge services are the best in the business and encompass a wide range of solutions designed with your goals in mind.

Technical consulting provides the required technical expertise to complete and implement specific test strategies.

Process consulting helps to integrate new R&D or manufacturing test processes and technology into your current environment.

Enterprise business consulting provides business-planning services focused on enterprise-wide test issues.

Training and education gives access to our depth of product expertise and helps keep you abreast of emerging technologies. Encompassing technology training, product training, measurement fundamentals and applications training, our classes can be delivered on-site or at an Agilent Training Center.

For more information on Agilent education and training visit:

www.agilent.com/find/education

PSA Series Ordering Information

PSA Series spectrum analyzer

E4443A 3 Hz to 6.7 GHz
 E4445A 3 Hz to 13.2 GHz
 E4440A 3 Hz to 26.5 GHz
 E4446A 3 Hz to 44 GHz
 E4448A 3 Hz to 50 GHz

Options

To add options to a product, use the following ordering scheme:
 Model E444xA (x = 0, 3, 5, 6 or 8)
 Example options E4440A-B7J, E4448A-1DS

Warranty & Service

Standard warranty is one year.
 R-51B-001-3C 1-year return-to-Agilent warranty extended to 3-years
 R-51B-001-5C 1-year return-to-Agilent warranty extended to 5-years

Measurement Personalities

E444xA-226	Phase noise	
E444xA-219	Noise figure	Requires 1DS
E444xA-241	Flexible modulation analysis	
E444xA-BAF	W-CDMA	Requires B7J
E444xA-210	HSDPA	Requires B7J and BAF
E444xA-202	GSM w/ EDGE	Requires B7J
E444xA-B78	cdma2000	Requires B7J
E444xA-214	1xEV-DV	Requires B7J and B78
E444xA-204	1xEV-DO	Requires B7J
E444xA-BAC	cdmaOne	Requires B7J
E444xA-BAE	NADC, PCD	Requires B7J
E444xA-211	TD-SCDMA	
E444xA-266	Programming code compatibility suite	

Hardware

E444xA-1DS	100 kHz to 3 GHz built-in preamplifier	
E444xA-B7J	Digital demodulation hardware	
E4440A-122	80 MHz bandwidth digitizer	E4440A only, excludes H70
E444xA-123	Switchable MW preselector bypass	E4440A/43A/45A only, excludes AYZ
E444xA-124	Y-axis video output	
E444xA-AYZ	External mixing	E4440A/46A/48A only, excludes 123
E4440A-BAB	Replaces type-N input connector with APC 3.5 connector	E4440A only
E444xA-H70	70 MHz IF output	Excludes 122

Connectivity Software

E444xA-230	BenchLink Web Remote Control Software	
E4440A-235	Wide BW digitizer external calibration wizard	Requires 122

Accessories

E444xA-1CM	Rack mount kit
E444xA-1CN	Front handle kit
E444xA-1CP	Rack mount with handles
E444xA-1CR	Rack slide kit
E444xA-045	Millimeter wave accessory kit
E444xA-0B1	Extra manual set including CD ROM

Calibration¹

R-50C-011-3	Inclusive calibration plan, 3 year coverage
R-50C-011-5	Inclusive calibration plan, 5 year coverage
R-50C-013-3	Inclusive calibration plan and cal data, 3 year coverage
R-50C-013-5	Inclusive calibration plan and cal data, 3 year coverage
E444xA-0BW	Service manual and calibration software
E444xA-UK6	Commercial calibration certificate with test data

1. Options not available in all countries

Product Literature

- *PSA Series*, brochure, literature number 5980-1283E
- *PSA Series*, data sheet, literature number 5980-1284E
- *Self-Guided Demonstration for Spectrum Analysis*, product note, literature number 5988-0735EN
- *Phase Noise Measurement Personality*, technical overview, literature number 5988-3698EN
- *Noise Figure Measurement Personality*, technical overview, literature number 5988-7884EN
- *Flexible Modulation Analysis Measurement Personality*, technical overview, literature number 5989-1119EN
- *W-CDMA and HSDPA Measurement Personalities*, technical overview, literature number 5988-2388EN
- *GSM with EDGE Measurement Personality*, technical overview, literature number 5988-2389EN
- *cdma2000 and 1xEV-DV Measurement Personalities*, technical overview, literature number 5988-3694EN
- *1xEV-DO Measurement Personality*, technical overview, literature number 5988-4828EN
- *cdmaOne Measurement Personality*, technical overview, literature number 5988-3695EN
- *NADC/PDC Measurement Personality*, technical overview, literature number 5988-3697EN
- *TD-SDCMA Measurement Personality*, technical overview, literature number 5989-0056EN
- *80 MHz Bandwidth Digitizer*, technical overview, literature number 5989-1115EN
- *Programming Code Compatibility Suite*, technical overview, literature number 5989-1111EN
- *PSA Series Spectrum Analyzers, Option H70, 70 MHz IF Output*, product overview, literature number 5988-5261EN
- *Optimizing Dynamic Range for Distortion Measurements*, product note, literature number 5980-3079EN
- *PSA Series Amplitude Accuracy*, product note, literature number 5980-3080EN
- *PSA Series Swept and FFT Analysis*, product note, literature number 5980-3081EN
- *PSA Series Measurement Innovations and Benefits*, product note, literature number 5980-3082EN
- *Signal Analysis Basics*, application note 150, literature number 5952-0292
- *8 Hints for Millimeter Wave Spectrum Measurements*, application note, literature number 5988-5680EN
- *Spectrum Analyzer Measurements to 325 GHz with the Use of External Mixers*, application note 1453, literature number 5988-9414EN
- *EMI*, application note 150-10, literature number 5968-3661E
- *Vector Signal Analysis Basics*, application note 150-15, literature number 5989-1121EN
- *Using Extended Calibration Software for Wide Bandwidth Measurements, PSA Option 122 & 89600 VSA*, application note 1443, literature number 5988-7814EN
- *PSA Series Spectrum Analyzer Performance Guide Using 89601A Vector Signal Analysis Software*, product note, literature number 5988-5015EN
- *89650S*, technical overview, literature number 5980-0723E
- *N5530S*, technical overview, literature number 5989-1113EN
- *Selecting the Right Signal Analyzer for Your Needs*, selection guide, literature number 5968-3413E
- *BenchLink Web Remote Control Software*, product overview, literature number 5988-2610EN
- *IntuiLink Software*, data sheet, literature number 5980-3115EN

For more information go to www.agilent.com/find/psa

Microsoft is a U.S. registered trademark of Microsoft Corp.
BLUETOOTH is a trademark owned by Bluetooth SIG, Inc., U.S.A. and licensed to Agilent Technologies.
cdma2000 is a registered trademark of the Telecommunications Industry Association (TIA-USA).

Agilent Technologies' Test and Measurement Support, Services, and Assistance

Agilent Technologies aims to maximize the value you receive, while minimizing your risk and problems. We strive to ensure that you get the test and measurement capabilities you paid for and obtain the support you need. Our extensive support resources and services can help you choose the right Agilent products for your applications and apply them successfully. Every instrument and system we sell has a global warranty. Support is available for at least five years beyond the production life of the product. Two concepts underlie Agilent's overall support policy: "Our Promise" and "Your Advantage."

Our Promise

Our Promise means your Agilent test and measurement equipment will meet its advertised performance and functionality. When you are choosing new equipment, we will help you with product information, including realistic performance specifications and practical recommendations from experienced test engineers. When you receive your new Agilent equipment, we can help verify that it works properly and help with initial product operation.

Your Advantage

Your Advantage means that Agilent offers a wide range of additional expert test and measurement services, which you can purchase according to your unique technical and business needs. Solve problems efficiently and gain a competitive edge by contracting with us for calibration, extra-cost upgrades, out-of-warranty repairs, and onsite education and training, as well as design, system integration, project management, and other professional engineering services. Experienced Agilent engineers and technicians worldwide can help you maximize your productivity, optimize the return on investment of your Agilent instruments and systems, and obtain dependable measurement accuracy for the life of those products.

Agilent T&M Software and Connectivity

Agilent's Test and Measurement software and connectivity products, solutions and developer network allows you to take time out of connecting your instruments to your computer with tools based on PC standards, so you can focus on your tasks, not on your connections. Visit www.agilent.com/find/connectivity for more information.

For more information on Agilent Technologies' products, applications or services, please contact your local Agilent office. The complete list is available at:

www.agilent.com/find/contactus



Agilent Email Updates

www.agilent.com/find/emailupdates

Get the latest on the products and information you select.

Phone or Fax

United States:

(tel) 800 829 4444

(fax) 800 829 4433

Canada:

(tel) 877 894 4414

(fax) 905 282 6495

China:

(tel) 800 810 0189

(fax) 800 820 2816

Europe:

(tel) 31 20 547 2111

Japan:

(tel) (81) 426 56 7832

(fax) (81) 426 56 7840

Korea:

(tel) (080) 769 0800

(fax) (080)769 0900

Latin America:

(tel) (305) 269 7500

Taiwan:

(tel) 0800 047 866

(fax) 0800 286 331

Other Asia Pacific Countries:

(tel) (65) 6375 8100

(fax) (65) 6755 0042

Email: tm_ap@agilent.com

Product specifications and descriptions in this document subject to change without notice.

© Agilent Technologies, Inc., 2001, 2002, 2003, 2004
Printed in USA, August 3, 2004
5980-1283E



Agilent Technologies